

Roofdor / SV – E Automatic Roof Access Hatches

What Size? **ANY SIZE!**

Roofdor / SV & Roofdor / E - Automatic Opening Roof Access Hatches are available as single leaf, double leaf or multi leaf doors.

Designed with weatherproofing in mind comprising a double skinned insulated aluminium lid construction filled with CFC and HCFC free insulation with a U-Value of 0.78 W/m²k to BS3958: Part 5: 1986. This offers a high level of thermal insulation against condensation and heat loss together with excellent sound absorption properties.

Roof hatches have a 200mm upstand as standard but **ANY SIZE can be manufactured** upon request

Hatches are fitted with gas spring assisted opening, together with a safety hold open stay which helps to prevent against accidental closure. Heavy duty aluminium hinges are fitted as standard to support the lid. The lid features an integral wrap over edge and neoprene seal ensuring full weather protection.

The Roofdor access hatches are available as Non Fire Rated, **1, 2 or 3 Hour Fire Resistance** for integrity to BS476: Parts 21 and 22: 1987

GWP (Global Warming Potential) of 3

ODP (Ozone Depletion Potential) of 0

Hatches can be manufactured from Stainless Steel (Grade 304 or 316) - Ideal for coastal areas

Roofdor / SV

Held shut by a heavy duty electromagnetic solenoid switch, which is designed to be wired into the FAS or BMS system (by others) and supplied with an internal handle for manual closing

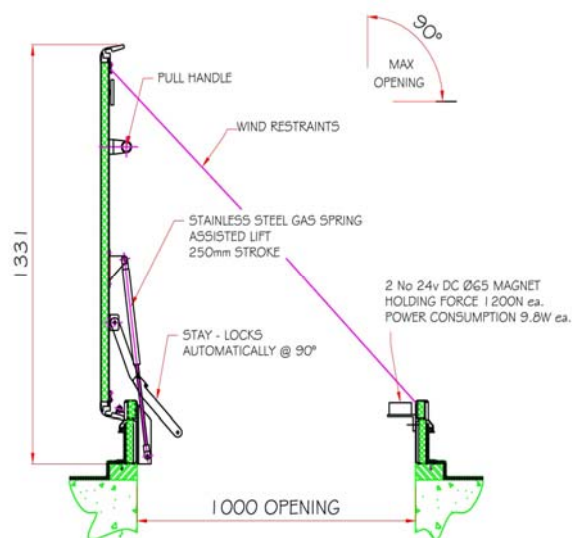
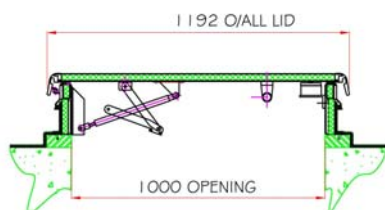

M & M Access Ltd
5 Quarry Park Close
Moulton Park Industrial Estate
Northampton
NN3 6QB

Tel: 01604 644944 Fax: 01604 644899

Email: sales@m-maccess.co.uk

Web: www.m-maccess.co.uk / www.access-panels.com

WIRING DIAGRAM FOR CONTROL BOX (MAGNETS)

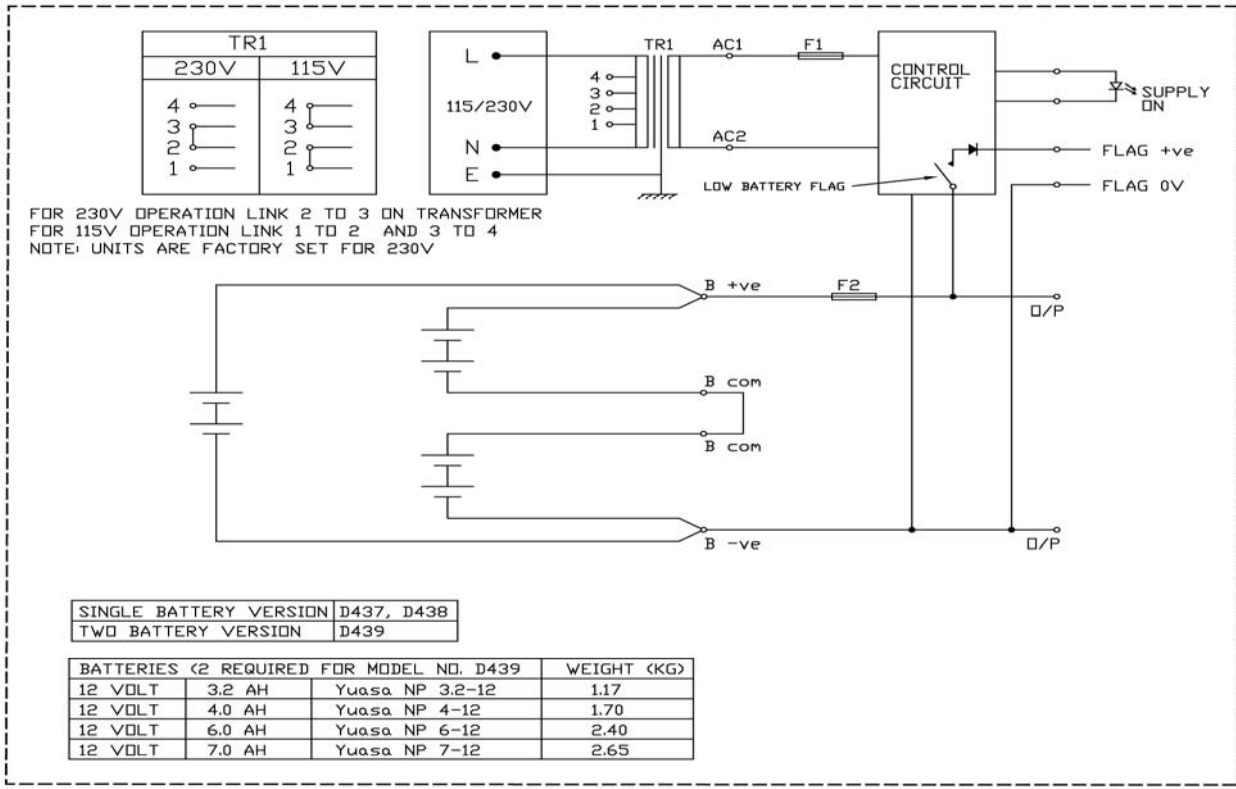

300 x 300 x 80 enclosure

Roofdor / E

Operated by a 24v DC Actuator working in tandem with the pneumatic gas springs to open the double skinned aluminum lid and is also designed to be wired into the FAS or BMS system (by others).

This access hatch cannot be manually closed

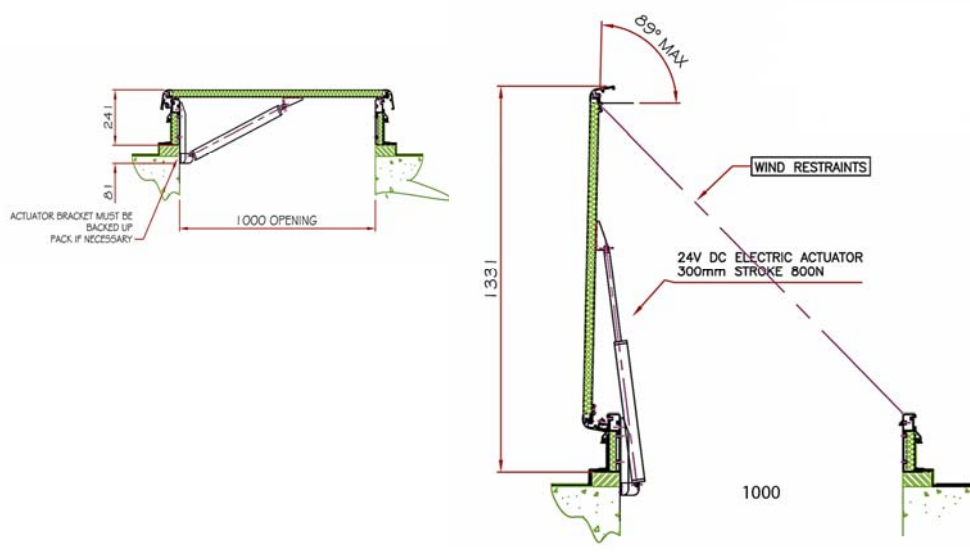

Electric Options

(Please Note Colour is for illustration purposes only)

SINGLE ACTUATOR / HAND CONTROL

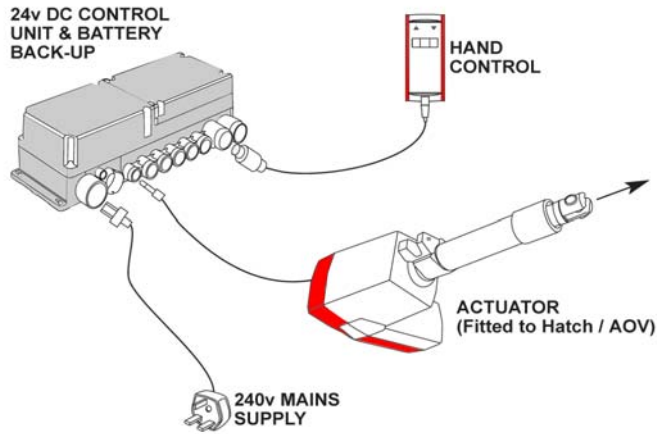

SINGLE ACTUATOR / SINGLE SWITCH

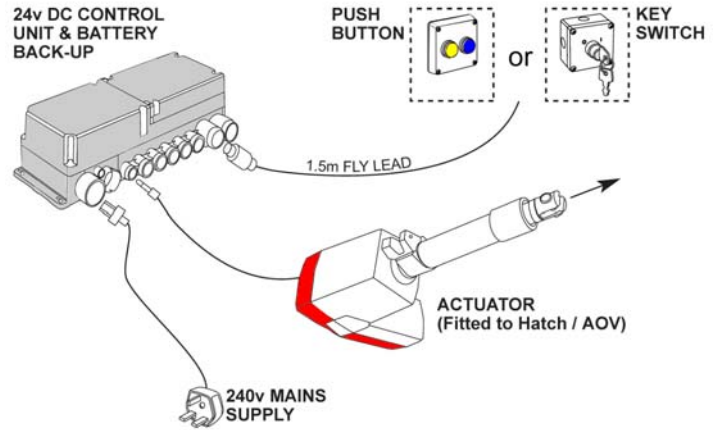

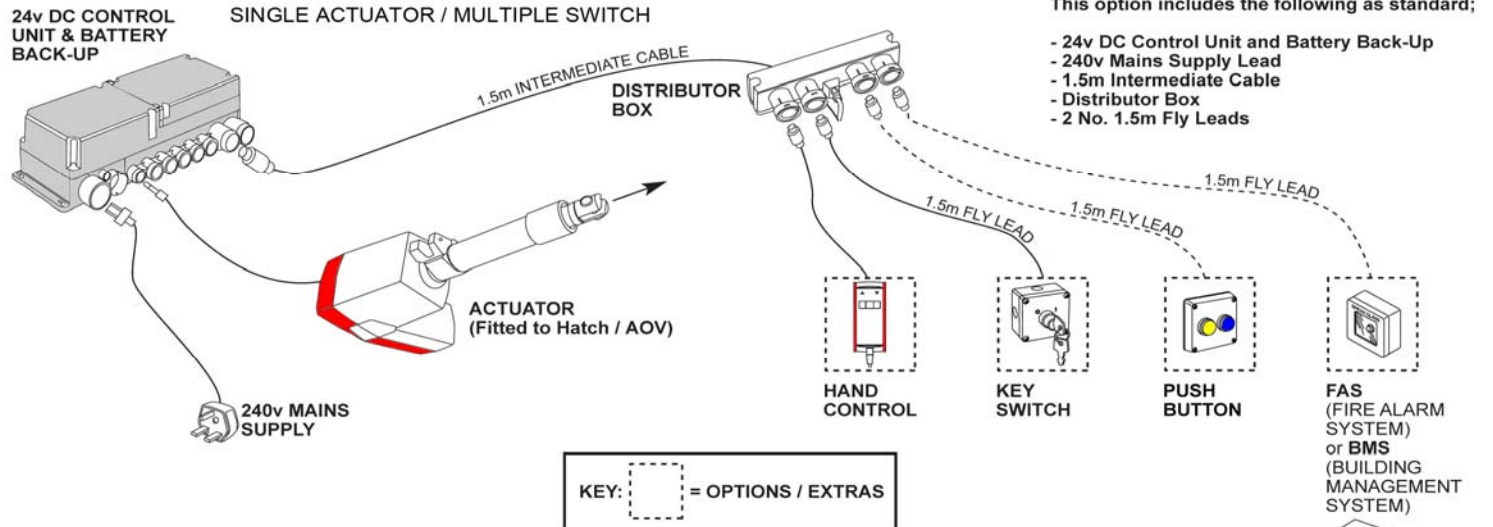

SINGLE ACTUATOR / MULTIPLE SWITCH



This option includes the following as standard;

- 24v DC Control Unit and Battery Back-Up
- 240v Mains Supply Lead
- 1.5m Intermediate Cable
- Distributor Box
- 2 No. 1.5m Fly Leads

OPTIONS / EXTRAS

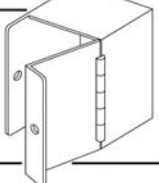
KEY SWITCH		PUSH BUTTON		FIRE (BREAK GLASS)		SECURITY BOX FOR SWITCHES	
------------	---	-------------	---	--------------------	--	---------------------------	---

Roofdor / 140°

Hatches are now available with a 140 degree opening.

Our 140° Smoke Vent is designed to stay open at a 140 degree angle to ensure that smoke and harmful gases are taken away from the opening and cannot be blown back into the building.

The cover opens to its fully open position within 60 seconds of activation in order to take smoke away from the building as quickly as possible.

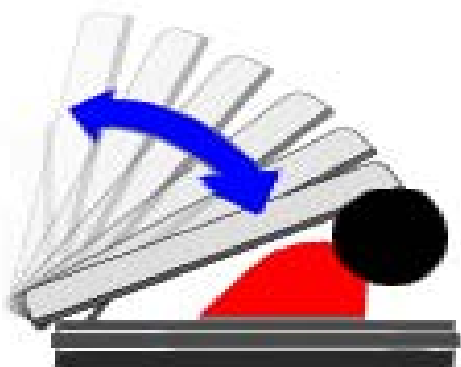
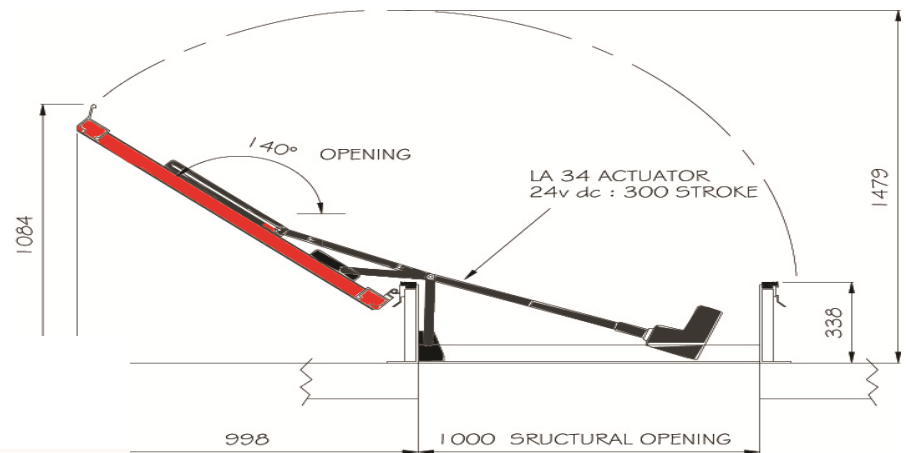
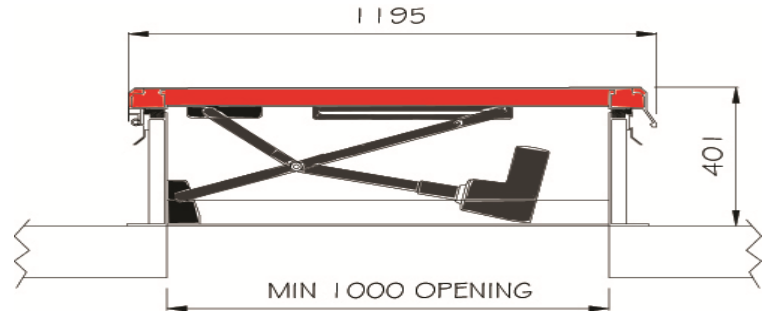

Electrically operated access hatches/smoke vents can have pressure sensitive edges incase on accidental closure

M & M Access Ltd can now manufacture vertically operated access hatches – Call our sales team today for more information

Roofdor Access Hatches can be supplied with various options

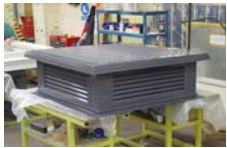

Access hatches can be manufactured with louvred panels for ventilation where required



Safety Grid / Ladder Extension – Perfect to assist you out of the Roofdor access hatches & also acts as a barrier when folded down



Access Hatches are designed to offer a high level of thermal insulation against heat loss & condensation. U-Values of 0.78 or 0.43W/m²K are available.



Hatches can be **1, 2 or 3 Hour Fire Resistance** for integrity to BS476: Parts 21 and 22: 1987



Curb Liner - To ease installation

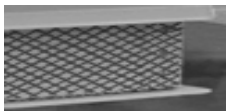

Expanded Mesh Curb Liner - Expanded mesh around the curb liner to aid adhesion for asphalt.



Hatches have a 200mm upstand as standard
We can manufacture hatches to have a smaller or larger upstand where required



Hatches can be single, double or multi leaf units



Hatches can be polyester powder coated to **ANY** standard stock RAL colour



Options for handrails & lockable gates are available



Retractable Handholds
Handholds can be fitted internally or permanently fixed externally



Sound reduction properties available

If you require an option that is not shown please call our sales team today & we would be happy to assist